

Jiří ŠVEC\*, Stanislav RUSZ\*\*, Ondřej HILŠER\*\*\*, Vladislav OCHODEK\*\*\*\*, Lucie KREJČÍ\*\*\*\*\*

MECHANICAL PROPERTIES OF STEEL DC01 FORMED BY DRECE METHOD

MECHANICKÉ VLASTNOSTI OCELI DC01 TVÁŘENÉ METODOU DRECE

### Abstract

The main goal of the paper is a review of current achieved results given by processing of steel DC01 by DRECE (Dual Rolls Equal Channel Extrusion) forming process, whose prototype equipment has been put in service in the end of 2009 at VŠB – Technical University of Ostrava, Faculty of Mechanical Engineering and Department of Mechanical Technology. The paper analyses the effect of the DRECE forming process on the mechanical properties and deep – drawing sheet metal formability of the steel DC01.

### Keywords

DRECE, DC01, Mechanical properties, ERICHSEN.

### Abstrakt

Príspevek uvádza súčasné výsledky ze zpracování oceli DC01 tvářecím procesem DRECE, jehož prototype byl na konci roku 2009 uveden do provozu pod záštitou VŠB – Technické university Ostrava, Fakulty strojní, Katedry mechanické technologie. Příspěvek analyzuje vliv tvářecí metody DRECE na mechanické vlastnosti a hlubokotažnost oceli DC01.

### Klíčová slova

DRECE, DC01, mechanické vlastnosti, ERICHSEN.

---

\* Ing., Department of Working and Assembly, Faculty of Mechanical Engineering, VŠB – Technical university of Ostrava, 17. listopadu 2172/15, Ostrava-Poruba, 708 33, Czech Republic, tel.: (+420) 59 732 4533, e-mail: jiri.svec1@vsb.cz

\*\* prof. Ing., CSc., Department of Mechanical Technology, Faculty of Mechanical Engineering, VŠB – Technical university of Ostrava, 17. listopadu 2172/15, Ostrava-Poruba, 708 33, Czech Republic, tel.: (+420) 59 732 3315, e-mail: stanislav.rusz@vsb.cz

\*\*\* Ing., Department of Mechanical Technology, Faculty of Mechanical Engineering, VŠB – Technical university of Ostrava, 17. listopadu 2172/15, Ostrava-Poruba, 708 33, Czech Republic, tel.: (+420) 59 732 9412, e-mail: ondrej.hilser@vsb.cz

\*\*\*\* Ing., Department of Mechanical Technology, Faculty of Mechanical Engineering, VŠB – Technical university of Ostrava, 17. listopadu 2172/15, Ostrava-Poruba, 708 33, Czech Republic, tel.: (+420) 59 732 3513, e-mail: vladislav.ochodek@vsb.cz

\*\*\*\*\* Ing., Ph.D., Department of Mechanical Technology, Faculty of Mechanical Engineering, VŠB – Technical university of Ostrava, 17. listopadu 2172/15, Ostrava-Poruba, 708 33, Czech Republic, tel.: (+420) 59 732 3525, e-mail: lucie.krejci@vsb.cz

# 1 INTRODUCTION

Severe Plastic Deformation (SPD) has been used to improve the mechanical properties of metals for a very long time, the best example is the Damascus sword which was produced already more than 2000 year ago and considered since as the first high – tech metallurgical product. SPD has gained again particular attention in metallurgy since the invention of the Equal Channel Angular Extrusion (ECAE) process by Segal in 1974 which permits to impose virtually unlimited shear strain to a metal in cyclic way. The process is also called Equal Channel Angular Pressing (ECAP) in the literature, both names are accepted. Segal's original contribution stimulated the scientific community to transform the microstructure of the material by SPD [1 – 2].

## 1.1 The ECAP process

ECAP is currently a popular manner to modify microstructure through refinement of the grain, as during the pressing no change of the cross – section of the formed workpiece takes place and the energy of deformation is accumulated inside the formed material. This leads to the start of a grain refinement processes. As it can be seen in the scheme of the ECAP (**Figure 1**), the workpiece is during the pressing being deformed through shearing, which appears in the place of the transition between the vertical and horizontal channel at an angle of  $90^\circ$ . Increased density of accumulated dislocations in the material leads to the creation of sub – grains, and thus to the disintegration of the former grain. As the sample did not change its cross – section after the transition, this process for the achievement of a high level of deformation, and thus final refinement of the microstructure, can be "freely" repeated [1 – 4].

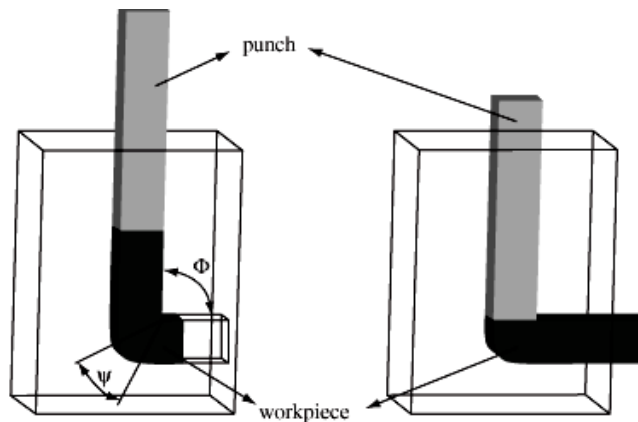

**Fig. 1** Principle of Equal Channel Angular Pressing method [4]

## 1.2 The CONFORM process

The principle of the CONFORM extrusion process is based on the action of a rotating wheel that drags and push the feed material by means of the frictional force existing between them. The CONFORM process has several advantages over the traditional extrusion processed.

The principle of the CONFORM extrusion, invented in UK, is shown in the **Figure 2**. An extrusion rotating wheel drags and push the feed material by means of the frictional force existing between them. The material is pushed into dies of various shapes.

The frictional force between the rod feed and the wheel must overcome not only the force required for the deformation but also the frictional force existing between the rod feed and the stationary dies. The extrusion occurs when the material meets the abutment and the die cavity. The product is continuous and welding phase of the billets is not required. A wide range of products may be

manufactured, such as wire, profiles, multi – void tubes and strips. During the process, heat is generated due to the friction between material and shoe, and due to the deformation.

One of the most serious problem in the process is due to the eventually excessive heat generation in the material; for this reason in a paper [6] a numerical analysis has been performed in order to evaluate some limits of the process and to study the quantity of heat generated by friction and by the imposed high strains. In this paper the choice of some operative parameters, such us die geometry, velocity and cooling rate of the dies, has been performed by means of an outranking approach [5 – 6] in order to select the best combination of them, by comparing the numerical results in the different cases.

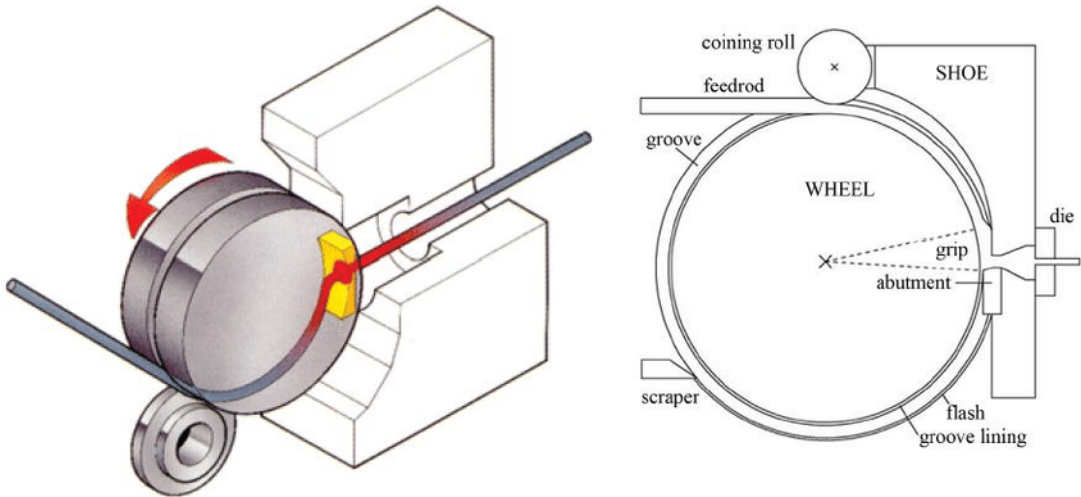

**Fig. 2** Principle of CONFORM forming method [5]

### 1.3 The DRECE process

The process of forming of material using the DRECE technique is based on making use of the material's intensive plastic deformation (**Fig. 3**), i.e. that this process is a combination of two known technologies, ECAP and CONFORM. As it has already been mentioned earlier, the equipment is a prototype possessed by the Faculty of Mechanical Engineering of the VŠB – Technical University Ostrava. The equipment consists of a NORD gearbox and an electromotor with speed frequency converter, which gives us the option to change the deformation rate even during the process, and thus allows us to flexibly react to the process progress. Other components include a plate clutch, a drive roller, two pressure rollers and a bottom and top forming tool. The pressure applied onto the front pressure roller is controlled by a pair of hydraulic cylinders; the pressure applied onto the rear pressure roller is controlled mechanically. The entire DRECE equipment is shown in **Figure 4**.

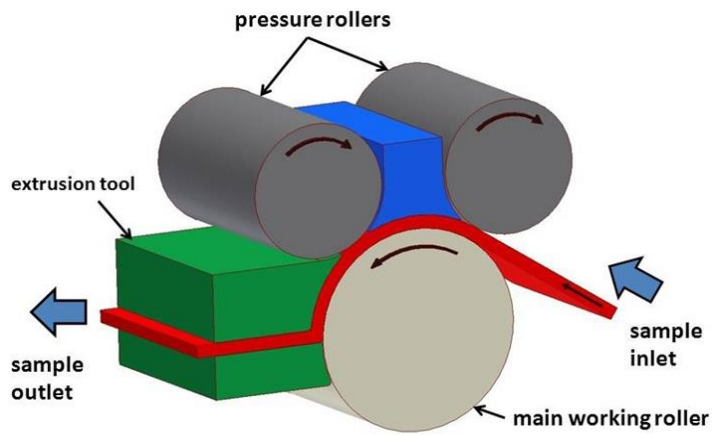

**Fig. 3** Principle of the DRECE process

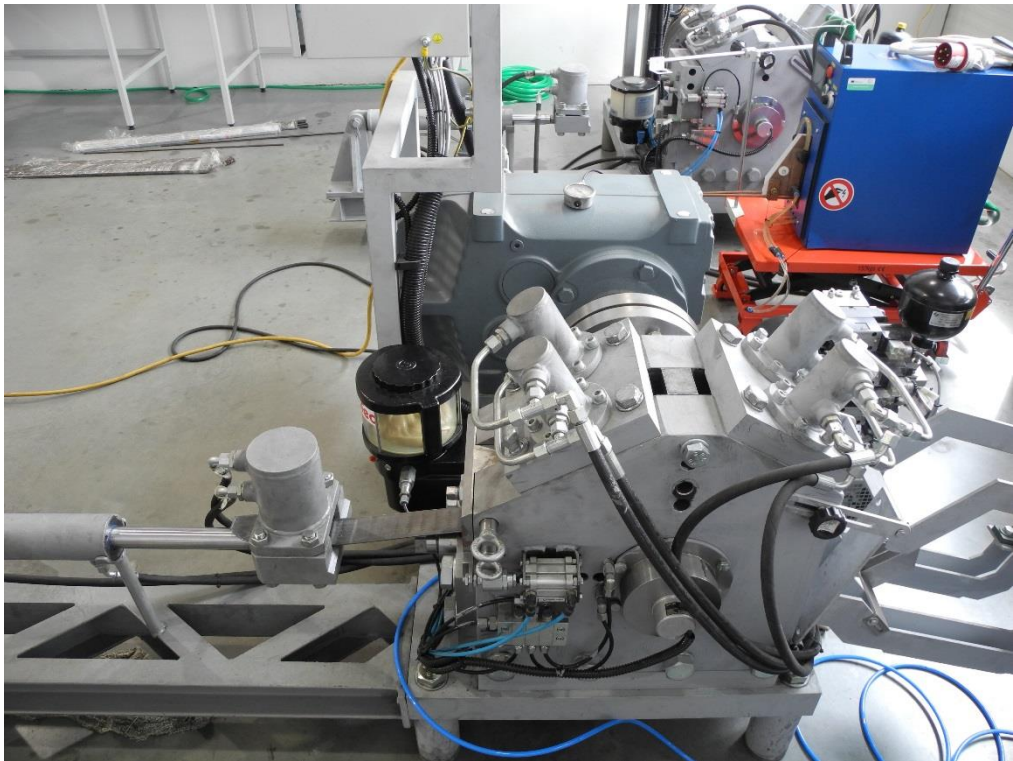

**Fig. 4** The DRECE equipment

## 2 INVESTIGATION PROCEDURE

### 2.1 Experimental material

For realization of the experiments were used a cold – rolled steel sheets of DC01 with dimensions 58 x 2 x 2000 mm. Chemical composition of the tested steel is presented in **Table 1**.

**Tab. 1** Chemical composition of the steel DC01

	<b>C</b>	<b>Mn</b>	<b>P</b>	<b>S</b>	<b>Al</b>	<b>Fe</b>
<b>Weight %</b>	0,100	0,210	0,008	0,013	0,059	rest.

### 2.2 Tensile testing

Mechanical properties (yield stress YS, ultimate tensile strength UTS, ductility A and hardness HV10) were evaluated in initial state and after application of the DRECE process. All the tensile tests were performed according to the ISO 6892 – 1 with using standardized test – pieces according to Annex D.

### 2.3 Technological test – deep drawing by ERICHSEN

Technological tests of the material have been proposed to verify formability of steel DC01. Erichsen deep – drawing test were carried out at the Center of the Plastometric Technology at the University of Žilina. Universal device BPM – TESA – Schweiz is shown in **Figure 5**.

Samples of the initial state of the experimental steel and samples after the 1<sup>th</sup> to the 6<sup>th</sup> passes by the forming tool were prepared. The samples to the Erichsen test were prepared with dimensions 58 mm × 58 mm × 2 mm.



a)

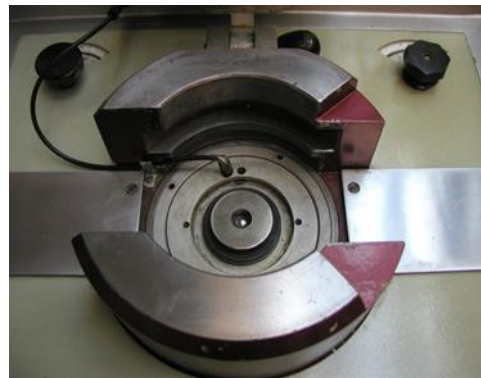

b)

**Fig. 5** The BPM – TESA – Schweiz device: a) Overall view, b) Detail of the mandrel

### 3 INVESTIGATION RESULTS

#### 3.1 Mechanical properties

The mechanical properties of experimental steel DC01 were measured on the specimens prepared from extrusion direction. **Table 2** present the mechanical properties (YS, UTS, A and HV) of DC01 in initial state and after DRECE processing.

**Tab. 2** Mechanical properties of the steel DC01

	YS [MPa]	UTS [MPa]	A [%]	HV10 [-]
<b>Initial state</b>	173	311	40	93
<b>1x DRECE</b>	293	366	19	127
<b>2x DRECE</b>	302	391	13	135
<b>4x DRECE</b>	324	421	9	134
<b>6x DRECE</b>	344	523	10	135

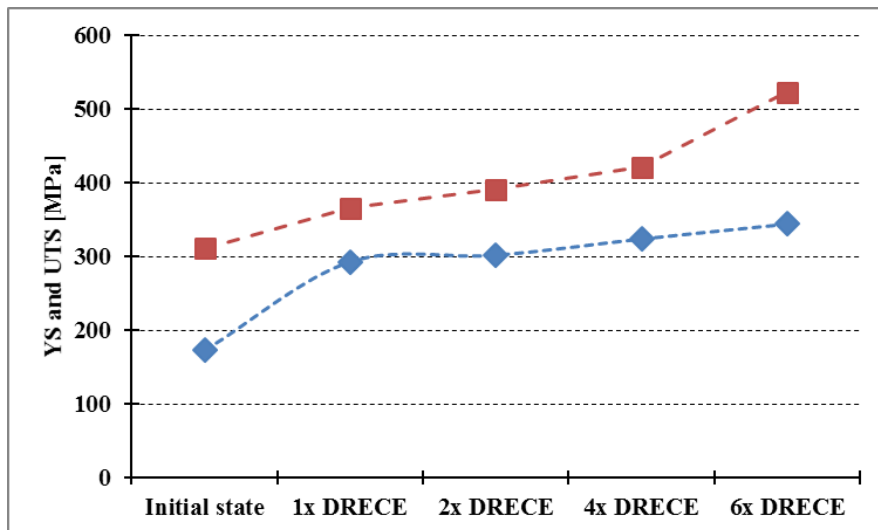

**Fig. 6** Yield Stress (YS - blue) and Ultimate Tensile Strength (UTS - red) evolution after individual DRECE passes

From the mechanical properties results (**Tab. 2** and **Fig. 6**) it is evident, that DRECE process has very significant influence on the strength properties (YS, UTS and HV) increasing. Actual results corresponding with our previously research goals [7], i. e. the dominant mechanism of the strengthening during DRECE processing is a deformation strengthening by dislocations accumulation in the deformed grains.

Results from tensile testing shown relatively strong decreasing of the plasticity after the first DRECE pass, from 40% to value approximately 19%. The ductility evolution present in **Figure 7** shown the negative effect of the DRECE processing on the steel plasticity.

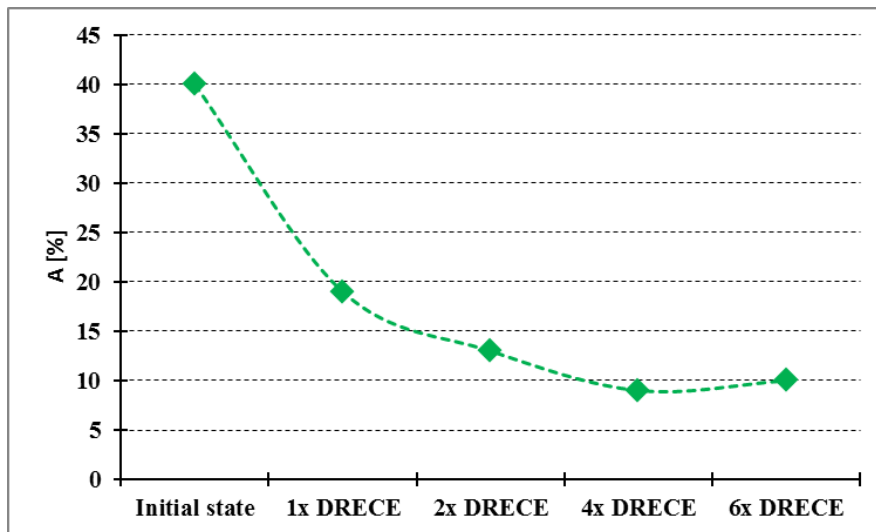

**Fig. 7** Ductility evolution after individual DRECE passes

### 3.2 Deep – drawing properties by ERICHSEN test

An indicator for assessment, whether the sheet metal is suitable for forming, is the size of the cup  $h$ ; according to the ČSN ISO 20482 standard, the parameter defining the depth of the cup in the sheet metal is designated as IE [mm]. In this test the parameter IE is not the only criterion for assessing the sheet metal's quality. The crack's propagation and shape is also assessed.

**Table 3** lists for illustration the values of IE and A. It is apparent that after the second pass through the DRECE tool, the index IE, as well as work A, decreased compared to the previous state. The value of the index IE decreases with the growing number of passes.

**Tab. 3** Deep – drawing properties of steel DC01 by ERICHSEN

	IE [mm]	A [J]
<b>Initial state</b>	13,56	263,6
<b>1x DRECE</b>	11,79	255,1
<b>2x DRECE</b>	10,36	242,1
<b>4x DRECE</b>	9,96	241,2
<b>6x DRECE</b>	10,02	240,9

From the ERICHSEN deep – drawing technological test results are evident, that IE parameter correlated with the plasticity of the deformed material. From the value 13,56 mm (initial state) to value 10,02 mm after the sixth pass by DRECE equipment. Deformation strengthening without recovery mechanisms leads to the negative decrease of the plasticity of steel DC01.

**Figure 8** present the IE deep – drawing parameter evolution in dependence on the DRECE passes. The results correspond with previously conclusions.

As it is seen from the **Figure 9**, a so-called concentrated crack was created – i.e. material is suitable for deep drawing process. A detailed description of the experimental results is shown in the paper [7].



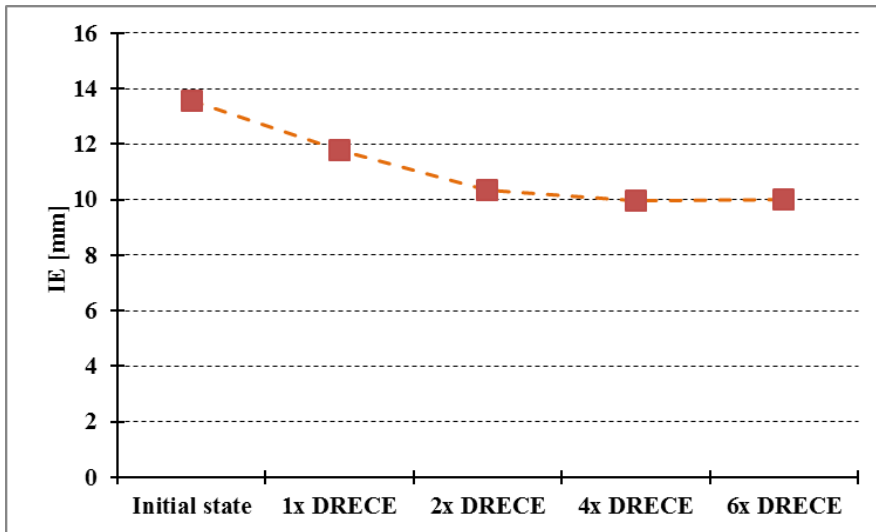

**Fig. 8** Ductility evolution after individual DRECE passes

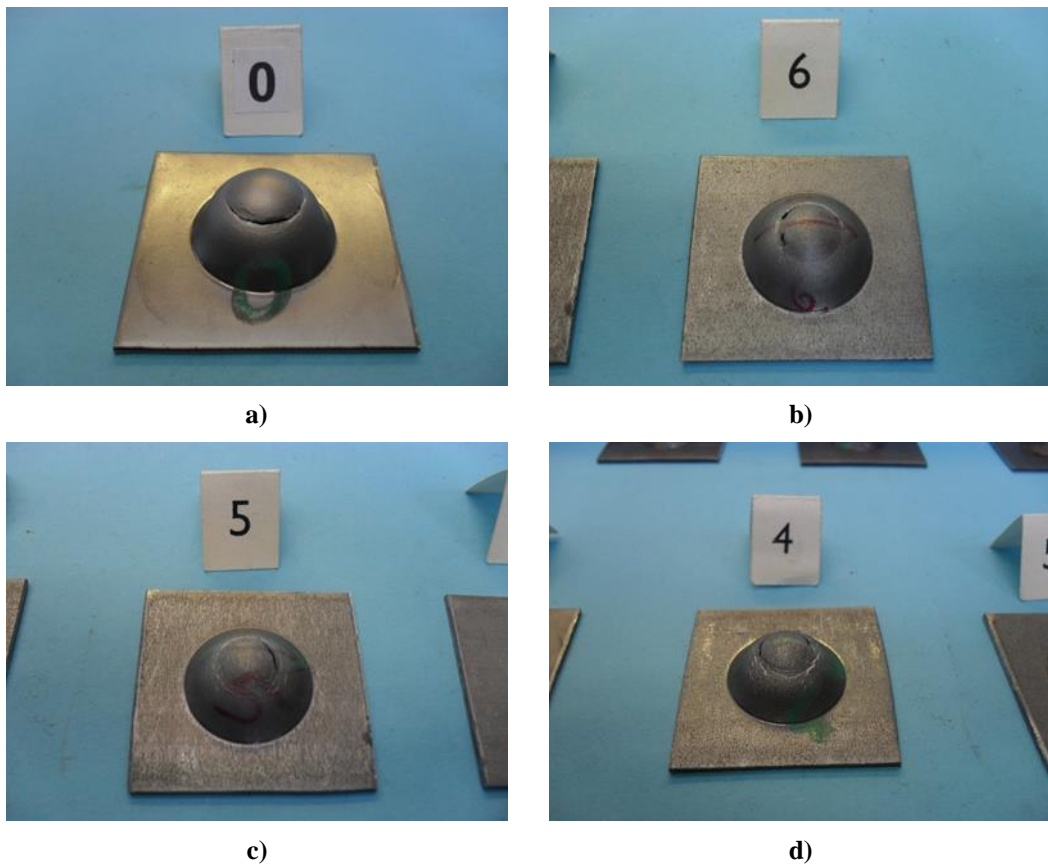

**Fig. 9** Crack of the steel DC01 after ERICHSEN test: a) initial state, b) after 2<sup>nd</sup>, c) 4<sup>th</sup>, d) 6<sup>th</sup> pass by DRECE



## 4 CONCLUSIONS

Results, presented in this paper, shows that Dual Rolling Equal Channel Extrusion (DRECE) process very significantly increase the strength properties of the sheets from steel DC01. Were achieved maximal yield stress 344 MPa and ultimate tensile strength 523 MPa after the 6<sup>th</sup> pass by DRECE process realized at room temperature. Increasing of strength properties is approx. 98% (yield stress) and of about 68 % (ultimate tensile strength) compared to an initial state.

The mechanical properties evolution after the individual DRECE passes point to effect of deformation (dislocation) strengthening mechanism without recovery, recrystallization processes, needed for grain refinement of materials processed by SPD methods.

Comparison between yield stress, ultimate tensile strength and ductility, present in **Figure 10**, shown, that optimal number for strength increasing while preserving the plasticity is the first pass through DRECE.

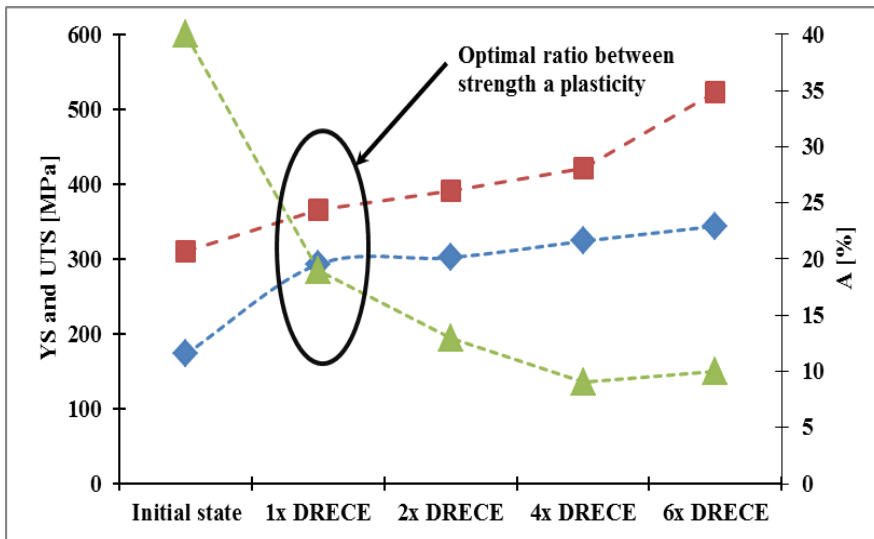
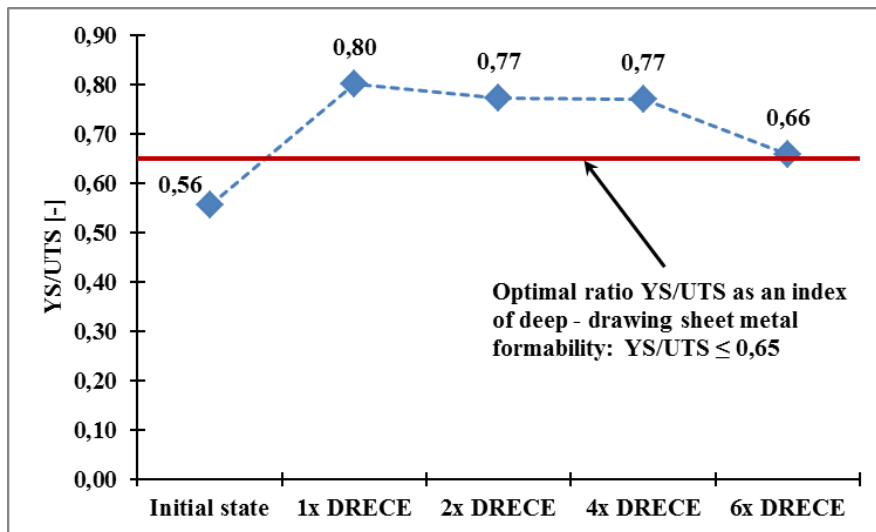

**Fig. 10** Graph of optimal number of DRECE passes for optimal mechanical properties achieving

The suitability of the sheet for use in deep – drawing process can be judged according to the yield stress / ultimate tensile strength (YS/UTS) ratio. Materials suitable for deep – drawing must have a ratio lower than value 0,65. With an increasing ratio value, the suitability of metal sheet for deep – drawing decreases.

From the results of the YS/UTS ratio for the steel DC01, depending on the number of DRECE passes shown in **Figure 11**. It is evident that with increasing number of passes, the deep – drawing formability of the sheet is substantially reduced due to the growth of the both strength parameters (YS and UTS). This fact leads to a reduction of the homogeneous plastic deformation area in the tensile diagram and thus to the loss of deep – drawing formability.

It is necessary to calculate with the reduction of the metal sheets deep – drawing formability after the DRECE processing.



**Fig. 11** Influence of the DRECE passes on the ratio YS/UTS (suitability of the steel DC01 to deep – drawing)

## ACKNOWLEDGEMENT

Results in the contribution were achieved at solving of specific research project No. SP2017/146 with the name of: „Výzkum a vývoj materiálových, výrobních technologií a jejich projektového řízení“ solved in year 2017 at the Faculty of Mechanical Engineering of VŠB Technical University of Ostrava.

## REFERENCES

- [1] TOTH, L. S. & GU, C. Ultrafine – grain metals by severe plastic deformation. *Materials Characterization*. 2014, Vol. 92, pp. 1 – 14. ISSN 1044 – 5803.
- [2] LANGDON, T. G. The principles of grain refinement in equal – channel angular pressing. *Materials Science and Engineering: A*. 2007, Vol. 462, No. 1 – 2, pp. 3 – 11. ISSN 0921 – 5093.
- [3] TAŇSKI, T., SNOPIŇSKI, P., BOREK, W. Strength and structure of AlMg3 alloy after ECAP and post – ECAP processing. *Materials and Manufacturing Processes*. 2017, Vol. 32, No. 12, pp. 1368 – 1374. ISSN 1042 – 6914.
- [4] VALIEV, R. Z., ISLAMGALIEV, R. K., ALEXANDROV, I. V. Bulk nanostructured materials from severe plastic deformation. *Progress in Materials Science*. 2000, Vol. 45, No. 2, pp. 103 – 189. ISSN 0079 – 6425.
- [5] SONG, L., YUAN, Y., YIN, Z. Microstructural evolution in Cu – Mg alloy processed by Conform. *International Journal of Nonferrous Metallurgy*. 2013, Vol. 2, No. 3, pp. 100 – 105. ISSN 2168 – 2054.
- [6] ČADA, R. Formability evaluation of low-carbon steel strip. In: *Transactions of the VŠB-Technical University of Ostrava: Mechanical Series*. Vol. 57, No. 1, 2011, pp. 19-28. ISSN 1210-0471.
- [7] HILŠER, O., RUSZ, S., SALAJKA, M., ČÍŽEK, L. Evaluation of the deep – drawing steel sheets processed by DRECE device. *Archives of Materials Science and Engineering*. 2014, Vol. 68, No. 1, pp. 31 – 35. ISSN 1897 – 2764.