

Adam BUREČEK*, Lumír HRUŽÍK**

NUMERICAL SIMULATION OF THE INFLUENCE OF AIR CONTENT IN THE OIL ON THE
DYNAMICS OF THE SYSTEM

NUMERICKÁ SIMULACE VLIVU OBSAHU VZDUCHU V OLEJI NA DYNAMIKU SYSTÉMU

Abstract

The objective of the paper is a numerical simulation of the influence air content in the oil and bulk modulus of oil on the dynamics of the system. The simulation is realized with Matlab SimHydraulics and verified by experiment. Input values for the mathematical model are detected experimentally.

Abstrakt

Předmětem příspěvku je numerická simulace vlivu obsahu vzduchu V oleji a modulu pružnosti oleje na dynamiku systému. Simulace je provedena V programu Matlab SimHydraulics a ověřena experimentem. Vstupní hodnoty pro matematický model jsou zjištěny experimentálně.

1 INTRODUCTION

For mineral oil which is very often used in hydraulic mechanisms as an energy carrier has typical air content in two forms. The first one is in the atomic form when the air is dissolved in oil or the other one is in the molecular form when the air is undissolved and it occurs in the form of bubbles. Oil which contains undissolved air is referred to as an "oil-air" mixture. This mixture is characterised by undesirable properties, especially higher compressibility which affects the static and mainly dynamic properties of hydraulic system. The compressibility is expressed in the form of bulk modulus, resistance to deformation, capacity or the concentration of undissolved air. Mentioned variables can describe a mathematical model of the behavior of hydraulic system [2], [3].

2 DISSOLVED AIR IN THE OIL

In this form, air represents chemical bond atoms of nitrogen and oxygen on molecules of oil. Dissolution of air in the oil is described by Henry's law

$$V_{vr} = V_k \cdot k \cdot \frac{p}{p_a}, \quad (1)$$

where:

V_{vr} – volume of air dissolved in the oil [m³],

V_k – volume of oil [m³],

p – pressure at the end action [Pa],

p_a – atmospheric pressure [Pa],

k – absorption coefficient (for a mixture of oil - the air is $k = [0.093 \div 0.11]$) [-].

* Ing. Adam BUREČEK, VŠB – Technical University of Ostrava, Faculty of Mechanical Engineering,
Department of Hydromechanics and Hydraulic Equipments, 17. listopadu 15, Ostrava,
tel. (+420) 59 732 4270, e-mail adam.burecek.st@vsb.cz

** doc. Dr. Ing. Lumír HRUŽÍK, VŠB – Technical University of Ostrava, Faculty of Mechanical Engineering,
Department of Hydromechanics and Hydraulic Equipments, 17. listopadu 15, Ostrava,
tel. (+420) 59 732 4384, e-mail lumir.hruzik@vsb.cz

The amount of air is slightly dependent on temperature but in the temperature range from 20 – 80°C this dependence is negligible. According to Henry's law the content of air in oil at atmospheric pressure and temperature of 10°C is about 11%. With increasing pressure the amount of dissolved air increases. During the violation of steady state in which the oil was saturated with air when the pressure or temperature changes, there is the release of air molecules and the formation of bubbles, thus creating a mixture of oil-air or on the contrary there is further dissolution of air in the oil. This process is dependent on time. The time of dissolution of air in the oil will be much longer in comparison to the release of air [2], [3].

3 UNDISSOLVED AIR IN THE OIL

The occurrence of undissolved air in the oil in the form of bubbles is most often caused by release of dissolved air during a pressure, temperature and flow velocity change. Air bubbles evolve into various leakages, oil aeration, incorrectly modified outflows, etc. Thus the resulting mixture substantially changes the properties of oil. The bubbles formation can be reduced by high working pressure or by breather device, called gas separators.

For those reasons, the oil is expected as a multiphase homogeneous mixture of oil and a small amount of air. This homogeneous mixture is relevant only for solving one-dimensional flow, i.e. in hydraulic circuits and systems. Bulk modulus of this mixture is given by [2], [4]:

$$K = K_O \frac{1 + \alpha \cdot \left(\frac{p_a}{p_a + p} \right)^{1/n}}{1 + \alpha \cdot K_O \cdot \frac{p_a^{1/n}}{n \cdot (p_a + p)^{(n+1)/n}}}, \quad (2)$$

where:

K – bulk modulus of the mixture [Pa],

K_O – bulk modulus of oil [Pa],

α – relative air content in the oil at atmospheric pressure, $\alpha = V_v / V_O$ [-],

V_v – volume of air at atmospheric pressure [m³],

V_O – volume of oil [m³],

n – polytropic coefficient [-],

p – pressure at the end action [Pa],

p_a – atmospheric pressure [Pa].

4 DESCRIPTION OF EXPERIMENTAL DEVICE

The device, on which the experiment was conducted, consists of a hydraulic power unit, pipe, valve, closing valves and measuring tube, see in Fig. 1.

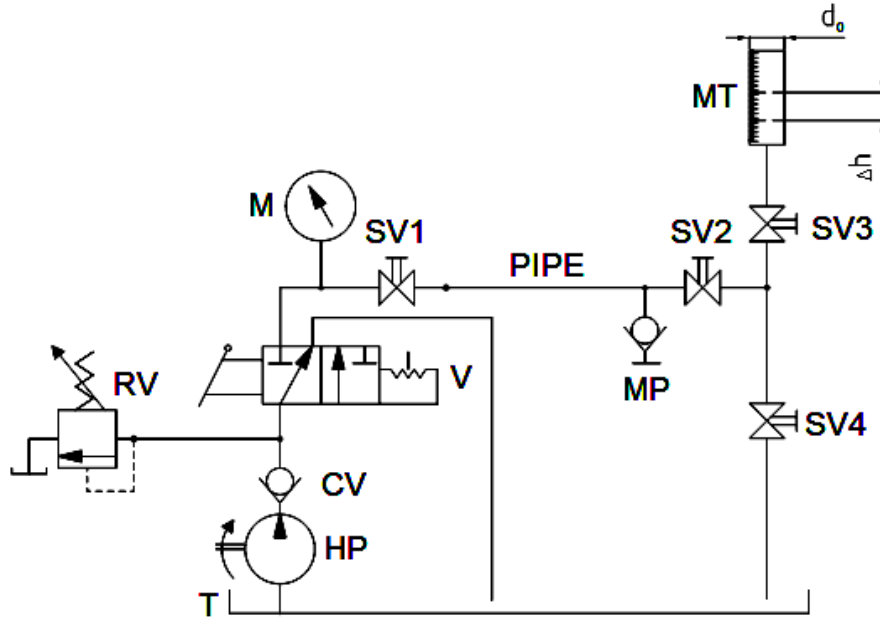

Fig. 1 Simplified scheme of experimental circuit.

(**Legend:** RV- Relief Valve, HP – Hydraulic Pump, M – Manometer, V – Directional Valve, SV1, SV2, SV3, SV4 – Stop Valve, MP – Measuring Point, MT – Measuring Tube, T – Tank).

At first on this device the bulk modulus of oil is experimentally detected. The measurement procedure is as follows. On relief valve RV we set the required pressure, convert the valve V and the flow is transferred into the circuit. Next, we close the valve SV2 and wait (1 – 2 seconds), till the flow stabilizes at zero. Then we close the valve SV4 and open the valve SV3, but it is necessary to ensure that the measuring tube remained sufficient oil volume for the measurement. Then we close the valve SV1 and open the valve SV2, compressed fluid leaks into a measuring tube MT, where the height of the oil level changes. The difference in fluid levels gives us Δh .

5 METHOD OF CALCULATION

Volume of oil in the pipe

$$V_{O,P} = \frac{\pi \cdot d_p^2 \cdot l_p}{4}, \quad (3)$$

Increase in oil volume due to compressibility oil and pipes

$$\Delta V_{O,P} = \frac{\pi \cdot d_o^2 \cdot \Delta h}{4}, \quad (4)$$

Bulk modulus of oil-pipe system

$$K_{O,P} = \frac{V_{O,P} \cdot \Delta p}{\Delta V_{O,P}}, \quad (5)$$

Bulk modulus of oil

$$K_O = \frac{1}{\frac{\Delta V_{O,P}}{V_{O,P} \cdot \Delta p} - \frac{d_p}{E_P \cdot s_P}}, \quad (6)$$

where:

d_p - diameter of pipe [m],

- l_p - pipe length [m],
- d_o - diameter of measuring tube [m],
- Δh - height increment the oil in a measuring tube [m],
- Δp - pressure drop [Pa],
- E_p - modulus of elasticity of pipe (for steel $2.1 \cdot 10^{11}$) [Pa],
- s_p - pipe wall thickness [m].

The measured value of the increment of oil in a measuring tube: $\Delta h = 0.043$ m.
 The calculated value of bulk modulus of oil: $K_o = 1.159 \cdot 10^9$ Pa [1].

6 DESCRIPTION OF SIMULATION MODEL

In compiling the simulation model see Fig. 2 the aim was to describe as accurately as possible the real circuit on which the experiment was performed.

The source is the hydraulic pump "HP" with a constant flow $2 \text{ dm}^3 \cdot \text{min}^{-1}$ which was measured experimentally. Oil flows through one-way valve "CV", hose "A1", supply pipe "A2", stop valve "SV1", pipe "PIPE", stop valve "SV2", waste pipe "B2" and hose "B1" to tank "T", "T1". Pipes and hoses are formed with segmented pipelines (6 segments per 1 m length). In case of close the valve "SV1" or "SV2" the oil flows through relief valve "RV". Next there are blocks for control valves "Control of SV1" and "Control of SV2", blocks for measuring flow and pressure "Measuring of Flow Rate" a "Measuring of Pressure", block solver "Solver Configuration" and block for definition of oil "Custom Hydraulic Fluid". The scanning time was set up by the "Time" block which is the same as in the experiment 0.001 S [4].

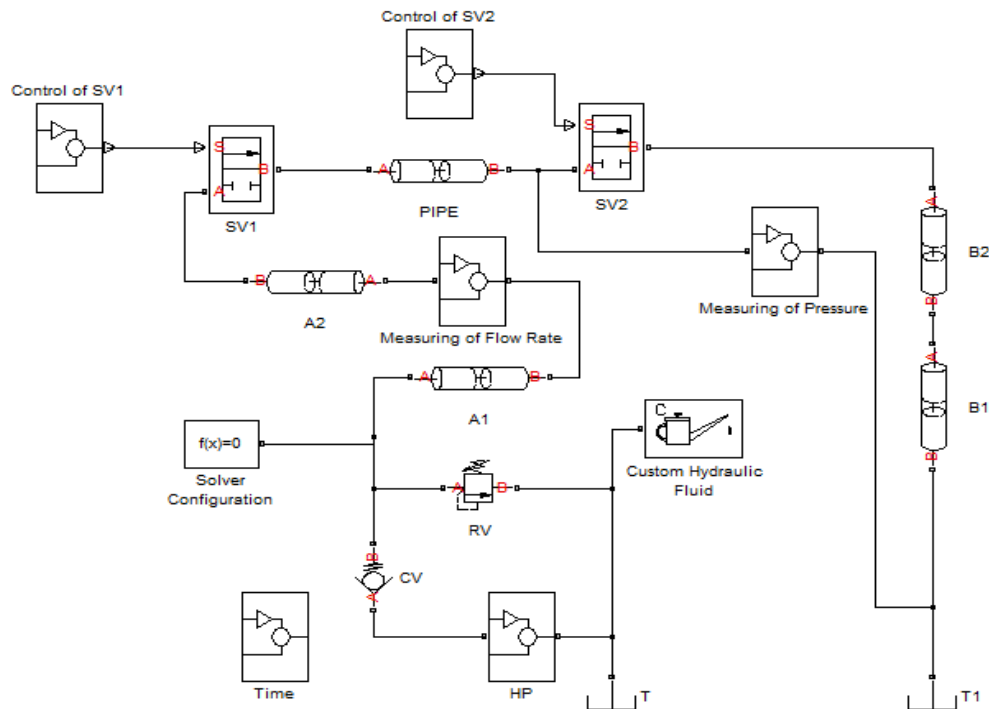

Fig. 2 Scheme of the simulation model.

7 THE RESULTS OF SIMULATION AND COMPARISON WITH EXPERIMENT

The dynamic pressure change is simulated on the model when the stop valve "SV2" is closed. There is an increase in pressure until a certain pressure is achieved, upon which point the relief valve "RV" 6 MPa is set to release. In Fig. 3 you can see that the pressure profile found by the experiment and the simulated pressure profile is the same. In Table 1 there is an oil setting parameter.

Simulation 1

Tab. 1 The oil parameters for the Simulation 1.

Fluid density	880	$\text{kg}\cdot\text{m}^{-3}$
Kinematic viscosity	$1.02\cdot 10^{-4}$	$\text{m}^2\cdot\text{s}^{-1}$
Bulk modulus	$1.159\cdot 10^9$	Pa
Relative amount of trapped air	0.00132	1

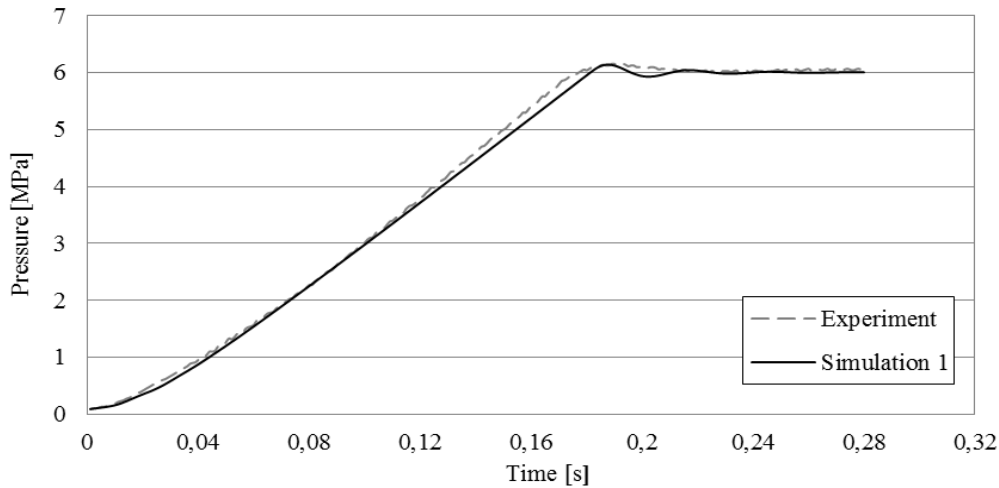

Fig. 3 Comparison profile of pressure simulation and experiment.

Simulation 2

In Simulation 2 the content of undissolved air is changed to 0.5 %. In Figure 4 you can see a comparison to Simulation 1, where content of undissolved air was set at 0.132 %.

Tab. 2 The oil parameters for the Simulation 2.

Fluid density	880	$\text{kg}\cdot\text{m}^{-3}$
Kinematic viscosity	$1.02\cdot 10^{-4}$	$\text{m}^2\cdot\text{s}^{-1}$
Bulk modulus	$1.159\cdot 10^9$	Pa
Relative amount of trapped air	0.005	1

Simulation 3

In Simulation 3 the bulk modulus of oil is changed at $1.6\cdot 10^9$ Pa, at the same air content, as in Simulation 1 and that is 0.132%.

Simulation 4

In Simulation 4 the bulk modulus of oil is recalculated according to equation (2), where for α a value of 0.005 and for K_O is value of $1.159\cdot 10^9$ Pa. The final bulk modulus $K = 1\cdot 10^9$ Pa is inserted to the simulation. The content of undissolved air is 0 %, because it is already counted in the bulk modulus K .

Tab. 3 The oil parameters for the Simulation 4.

Fluid density	880	$\text{kg}\cdot\text{m}^{-3}$
Kinematic viscosity	$1.02\cdot 10^{-4}$	$\text{m}^2\cdot\text{s}^{-1}$
Bulk modulus	$0.85\cdot 10^9$	Pa
Relative amount of trapped air	0	1

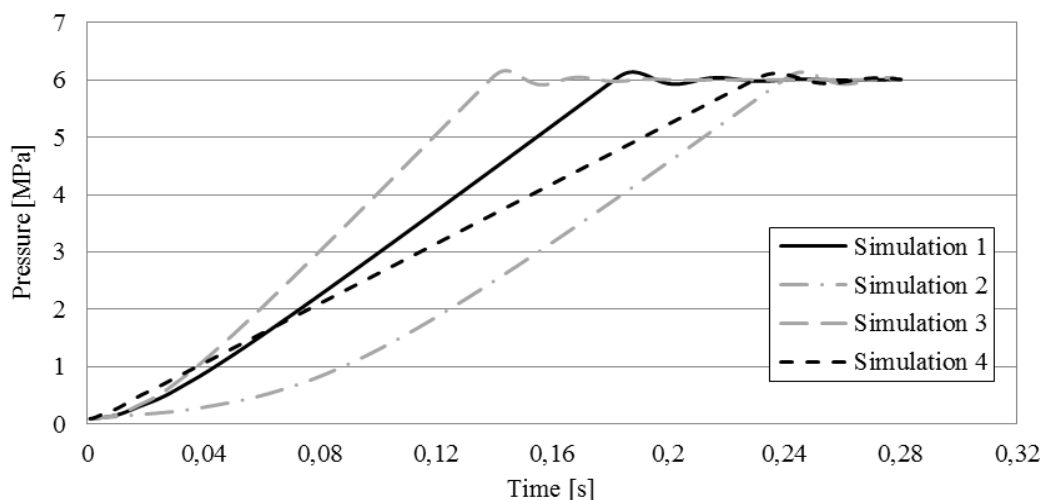

Fig. 4 Comparison of simulated pressure.

8 CONCLUSION

In the course of this experiment the value of the bulk modulus of oil and pressure profile at the closure of the valve SV2, were found. Next a simulation model was created, which corresponds to the experiment see in Fig. 3. Subsequently, simulations were performed in which the bulk modulus of oil (Simulation3) or content of undissolved air (Simulation 2) were modified. In Simulation 4, value of undissolved air contained in the bulk modulus according to equation (2) was modified. We can compare the results directly, when we set oil specify with bulk modulus and content of undissolved air (Simulation 2) or only bulk modulus (Simulation 4). The results of all simulations are compared in Fig. 4.

ACKNOWLEDGEMENTS

The work presented in this paper was supported by a grant SGS "Zkoumání fyzikálních vlastností materiálů a jejich vlivů na dynamiku proudění" SP2011/61.

REFERENCES

- [1] HRUŽÍK, L., VAŠINA, M. Nondestructive Testing for Experimental Determination of Elastic Modulus of Rubber Hoses. *ACTA HYDRAULICA ET PNEUMATICA*, 2009, Vol. 1/2009, Nr. 7, pp. 12 -16. ISSN 1336 – 7536.
- [2] KOZUBKOVÁ, M. *Matematické modely kavitace a hydraulického rázu*. Ostrava: VŠB – TU Ostrava, 2009. 130 pp. ISBN 978-80-248-2043-9
- [3] KOPÁČEK, J. Vzduch v minerálním oleji a jeho měření. *Strojírnoství* 36, 1986, Nr. 1, pp. 656-662.
- [4] The MathWorks, USA. (2007) *Matlab Simulink User's Guide, SimHydraulics User's Guide*, Reference.