

František FOJTÍK\*, Jan FUXA\*\*

NEW MODIFICATION OF CONJUGATED STRENGTH CRITERION

NOVÁ ÚPRAVA KONJUGOVANÉHO KRITÉRIA PEVNOSTI

**Abstract**

The paper describes the experimental results for the combined loading of the specimen manufactured from the construction steel 11523, melt T31052. The first set of the specimen was loaded by the alternating torque amplitude. The second and third set of specimen was loaded by the combination of the bending moment and of the torque for two slants of 30 and 60 degrees in the conditions of the alternating cycle. The fourth set was loaded by the alternating amplitude of the bending moment.

The conjugated strength criterion was applied on the experimental results. Further, new approximation based on the same boundary conditions as the described conjugated strength criterion was proposed. The required input parameters for the conjugated strength criterion were obtained from the stress-strain analysis of the specimen by the finite element method.

**Abstrakt**

Článek popisuje výsledky experimentů při kombinovaném zatěžování zkušebních vzorků vyrobených z konstrukční oceli 11523, tavba T31052. První sada zkušebních vzorků byla zatěžovaná střídavou amplitudou krouticího momentu. Druhá a třetí sada zkušebních vzorků byla namáhána kombinací ohybu a krutu, pro dva úhly sklonu 30° a 60° v podmínkách střídavého cyklu. Čtvrtá sada vzorků byla zatěžována střídavou amplitudou ohybového momentu.

Na výsledky experimentů bylo aplikováno konjugované kritérium pevnosti. Dále byla navržena nová aproximace, která vychází ze stejných okrajových podmínek jako popsané konjugované kritérium pevnosti. Pro získání potřebných vstupních hodnot do konjugovaného kritéria pevnosti byla počítána napěťově deformační analýza zkušebních vzorků metodou konečných prvků.

**1 INTRODUCTION**

For the verification of the multiaxial conjugated strength criterion the testing device SCHENCK was equipped by a special testing jaws [1, 2, 3, 4]. Those jaws make possible to load the specimen by the torsion or bending or by the combination of torsion and bending. The contribution describes four sets of experiments. The first experiment lies in the loading of the specimen by the alternation amplitude of the torque. From the experimental results the constants for the conjugated strength criterion and new approximation were obtained. The criterion and its modification was consequently applied in the results of another three experiments (bending and the combination torsion-bending under the slant angle 30 and 60 degrees in the conditions of alternation cycle). The specimen were manufactured from the steel 11523, with the geometry stated in Fig. 1

---

\* Ing., Ph.D., VŠB-Technical University of Ostrava, Department of Mechanics of Materials, 17. listopadu 15, CZ-708 33 Ostrava-Poruba, (+420) 59 732 3292, frantisek.fojtik@vsb.cz

\*\* prof., Ing., CSc., VŠB-Technical University of Ostrava, Department of Mechanics of Materials, 17. listopadu 15, CZ-708 33 Ostrava-Poruba, (+420) 59 732 4412, jan.fuxa@vsb.cz

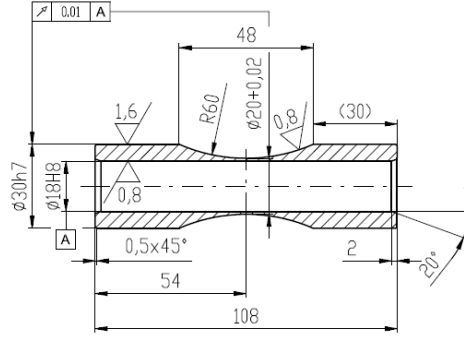

Fig. 1 Testing specimen

## 2 CONJUGATED STRESS CRITERION

In the following the conjugated strength criterion applied in the fatigue loading will be presented. This strength criterion [5, 6] can be written for the crack initiation in  $N$ -th cycle in the form:

$$S_{\sigma} = A_N - B_N \cdot \sigma_R, \quad (1)$$

where  $S_{\sigma}$  marks the stress intensity and is defined as [7]:

$$S_{\sigma} = 2^{-1/2} \cdot \left[ \frac{(\sigma_1 - \sigma_2)^2 + (\sigma_2 - \sigma_3)^2}{+(\sigma_3 - \sigma_1)^2} \right]^{1/2}. \quad (2)$$

$\sigma_R$  is the reference stress value producing the identical value as the octaedric normal stress and is defined as:

$$\sigma_R = (\sigma_1 + \sigma_2 + \sigma_3)/3, \quad (3)$$

where  $\sigma_1, \sigma_2, \sigma_3$  are the principal stresses. The value  $A_N$  can be considered as dependent on the cycle number  $N$  and is written as:

$$A_N = (A_0 + A_C)/2 + (A_0 - A_C)/2 \cdot \cos\left\{\pi \cdot \left[\log(4 \cdot N)/\log(4 \cdot N_C)\right]^a\right\}, \quad (4)$$

$A_0$  is the constant of the static reference strength criterion and can be determined based on the torsion test:

$$A_0 = 3^{1/2} \cdot \tau_f. \quad (5)$$

$A_C$  the stress intensity at the fatigue limit in torsion,  $N_C$  number of cycles at the fatigue limit,  $a$  material constant,  $B_N$  is the constant equal to:

$$B_N = 3 \cdot \left(\sqrt{3} \cdot \tau_f / \sigma_f - 1\right), \quad (6)$$

where  $\sigma_f$  is the value of real strength in tension and  $\tau_f$  is the value of real shear strength.

The criterion described above was set according to the first experiment – alternation torsion and this constant setting was then applied in the results of another experiments.

The new approximation curve was proposed where the value an  $A_{N1}$  is also depending of the number of cycles for the described criterion. The new approximation curve is proposed in the following shape:

$$A_{N1} = A_0 - (A_0 - A_C) \cdot \sin\left\{\pi/2 \cdot \left[\log(4 \cdot N)/\log(4 \cdot N_C)\right]^{a2}\right\}, \quad (7)$$

The absolute value of mean relative error of the used approximation can be determined as follows:

$$CH_F = ABS(S_{\sigma_i} - S_{\sigma_{Fi}}) / S_{\sigma_i} \cdot 100\% , \quad (8)$$

where  $S_{\sigma_i}$  are the calculated values of the stress intensities stated in the appropriate table and  $S_{\sigma_{Fi}}$  are the calculated values according to the Fuxa's approximation (4). The error of the new approximation is calculated in the similar way  $CH_N$ .

### 3 ALTERNATING TORSION

The specimen were loaded by the amplitude of the torque in the conditions of alternating cycle with the frequency of 25 Hz. The amplitude of the torque was stepwise reduced until the number of cycles  $10^7$  was achieved. The experimental results and the mean relative error values are summarized in Tab. 1. The stress intensities calculated according to the Fuxa's approximation (4)  $S_{\sigma_{Fi}}$  and according to the new approximation (7)  $S_{\sigma_{Ni}}$  are depicted in this table. According to this experiment the constants for both approximations were set.

The principal stresses  $\sigma_1, \sigma_2, \sigma_3$ , necessary for the stress intensity and reference stress calculation were determined by the stress-strain analysis using the finite element method in software ANSYS.

**Tab. 1** Experimental results for alternating torsion

Nr.	$S_{\sigma}$ /MPa	$S_{\sigma_{Fi}}$ /MPa	$S_{\sigma_{Ni}}$ /MPa	$\sigma_R$ /MPa	Number of Cycles	$Ch_F$ /%	$Ch_N$ /%	Notes
1	313,4	316,9	320,7	0	92200	1,12	2,3	
2	281,8	278,9	281,8	0	351800	1,02	0,01	
3	270,6	263,6	265,5	0	749450	2,59	1,9	
4	262,2	250,8	251,5	0	1944600	4,37	4,1	
5	246,6	246,2	246,4	0	11000000	0,15	0,07	No crack generated

The calculated results in the form of stress intensities according to the experimental results are mentioned in the Fig. 2. This results are approximated by the conjugated stress criterion using the Fuxa's (4) and the new approximation (7).

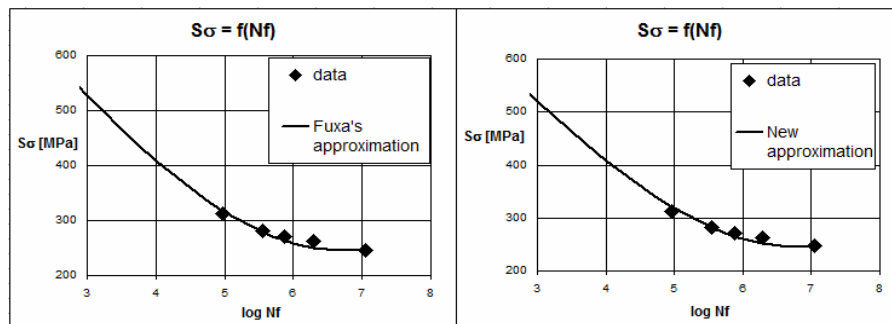

**Fig. 2** S-N curve for alternating torsion

### 4 ALTERNATING TORSION AND BENDING UNDER ANGLE OF 30 DEGREES

The identical specimen as in previous case were used in this experiment. However the specimen were fixed under the angle of 30 degrees against the axes of rotation and were loaded by the alternating amplitude of the combined moment until the crack initiation. The amplitude of the com-

bined moment (torque and bending moment) was stepwise reduced until the number of cycles  $10^7$  was achieved. The experiments were realized with the testing frequency of  $25 \text{ Hz}$ . The experimental results and the mean relative error values are summarized in Tab. 2. The stress intensities calculated according to the Fuxa's approximation (4)  $S_{\sigma F}$  and according to the new approximation (7)  $S_{\sigma N}$  are depicted in this table.

The principal stresses  $\sigma_1, \sigma_2, \sigma_3$ , necessary for the stress intensity and reference stress calculation were determined by the stress-strain analysis using the finite element method in software ANSYS as well. In the Fig. 3 the measured values and the curve of Fuxa's (4) and new (7) approximation are depicted. The identical constants as in previous cases are used in the approximation.

**Tab. 2** Experimental results for alternating torsion and bending for 30 degrees

Nr.	$S_{\sigma}$ /MPa	$S_{\sigma F}$ /MPa	$S_{\sigma N}$ /MPa	$\sigma_R$ /MPa	Number of Cycles	$Ch_F$ /%	$Ch_N$ /%	Notes
1	337,9	355,3	358,9	80,7	56100	5,13	6,22	
2	307,5	302,6	305,6	73,5	290400	1,16	0,61	
3	300,8	280,6	282,4	71,9	821400	6,69	6,09	
4	285,6	275,6	277,1	68,2	1069800	3,48	2,97	
5	277,1	263,1	263,2	66,2	4005000	5,07	5,02	
6	265,3	262,3	262,4	63,4	10146000	1,13	1,07	No crack generated

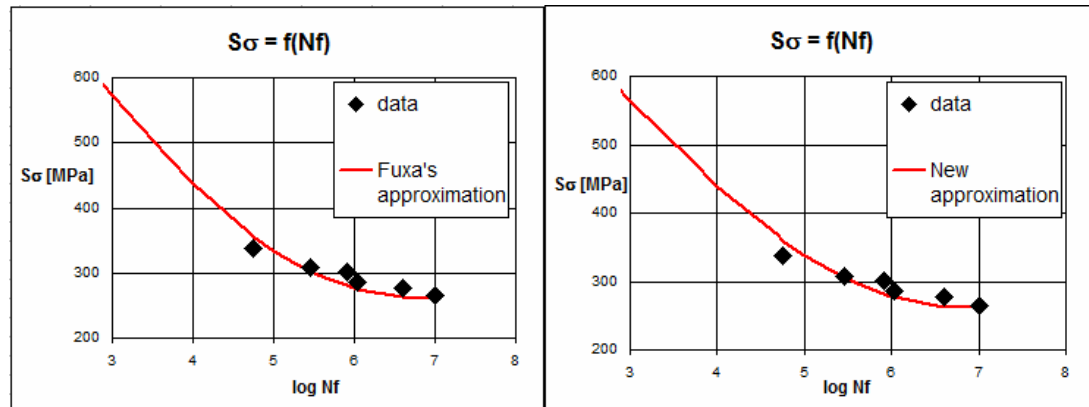

**Fig. 3** S-N curve for alternating torsion and bending for 30 degrees

## 5 ALTERNATING TORSION AND BENDING UNDER ANGLE OF 60 DEGREES

The identical specimen as in previous case were used in this experiment. The specimen were fixed under the angle of 60 degrees against the axes of rotation and were loaded by the alternating amplitude of the combined moment until the crack initiation. The amplitudes stepwise reduced until the number of cycles  $10^7$  was achieved. The experiments were realized with the testing frequency of  $25 \text{ Hz}$  as well. The experimental results and the mean relative error values are summarized in Tab. 3. The stress intensities calculated according to the Fuxa's approximation (4)  $S_{\sigma F}$  and according to the new approximation (7)  $S_{\sigma N}$  are depicted in this table.

The principal stresses  $\sigma_1, \sigma_2, \sigma_3$ , necessary for the stress intensity and reference stress calculation were determined by the stress-strain analysis using the finite element method in software ANSYS. In the Fig. 4 the measured values and the curve of Fuxa's (4) and new (7) approximation are depicted again. The identical constants as in previous cases are used in the approximation.

**Tab. 3** Experimental results for alternating torsion and bending for 60 degrees

Nr.	$S_{\sigma}$ /MPa	$S_{\sigma F}$ /MPa	$S_{\sigma N}$ /MPa	$\sigma_R$ /MPa	Number of Cycles	$Ch_F$ /%	$Ch_N$ /%	Notes
1	354,5	386,6	389,9	123,2	33100	9,04	9,97	
2	332,0	341,4	345,2	115,6	108600	2,84	3,97	
3	329,9	339,4	343,2	114,7	114900	2,88	4,01	
4	303,2	293,2	295,3	105,4	657500	3,30	2,60	
5	290,6	273,8	274,2	101,0	2827300	5,75	5,62	
6	279,3	271,6	271,9	97,1	11819000	2,73	2,63	No crack generated

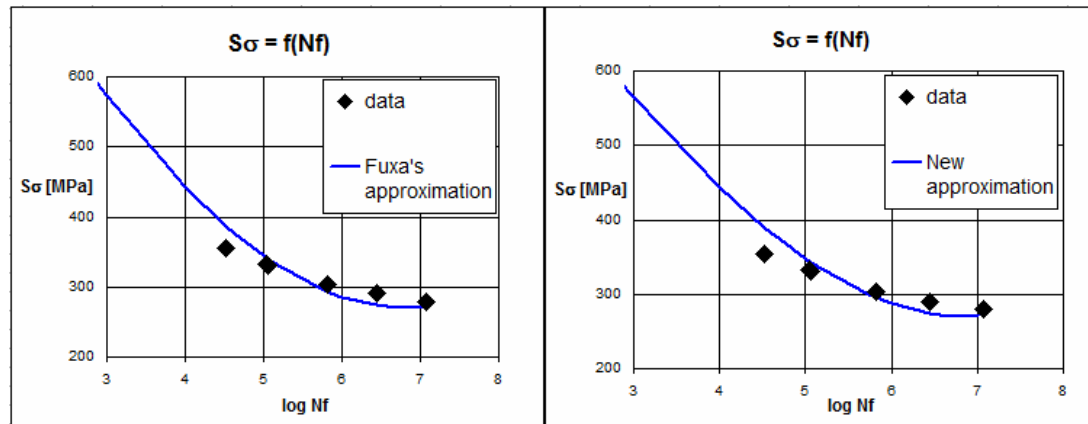

**Fig. 4** S-N curve for alternating torsion and bending for 60 degrees

## 6 ALTERNATING BENDING

The specimen were manufactured from the steel 11523, with the geometry stated in Fig. 1. The specimen were fixed to the testing jig under the angle of 90 degrees and were loaded by the alternating amplitude of the bending moment until the crack initiation. The amplitude of the bending moment was stepwise reduced until the number of cycles  $10^7$  was achieved. The experiments were realized with the testing frequency of 25 Hz. The experimental results and the mean relative error values are summarized in Tab. 4. The stress intensities calculated according to the Fuxa's approximation (4)  $S_{\sigma F}$  and according to the new approximation (7)  $S_{\sigma N}$  are depicted in this table.

The principal stresses  $\sigma_1$ ,  $\sigma_2$ ,  $\sigma_3$ , necessary for the stress intensity and reference stress calculation were determined by the stress-strain analysis using the finite element method in software ANSYS as well. In the Fig. 5 the measured values and the curve of Fuxa's (4) and new (7) approximation are depicted. The constant determined in previous case are used in the approximation.

**Tab. 4** Experimental results for alternating bending

Nr.	$S_{\sigma}$ /MPa	$S_{\sigma F}$ /MPa	$S_{\sigma N}$ /MPa	$\sigma_R$ /MPa	Number of Cycles	$Ch_F$ /%	$Ch_N$ /%	Notes
1	362,7	353,0	356,8	135,8	89700	2,67	1,63	
2	339,1	326,6	330,1	126,9	196635	3,67	2,66	
3	324,1	322,8	326,2	121,6	214430	0,40	0,63	
4	312,5	285,9	287,2	117,0	1262300	8,51	8,10	
5	307,0	275,0	275,1	114,9	5037000	10,41	10,40	
6	299,2	275,4	275,7	112,0	12100000	7,94	7,85	No crack generated

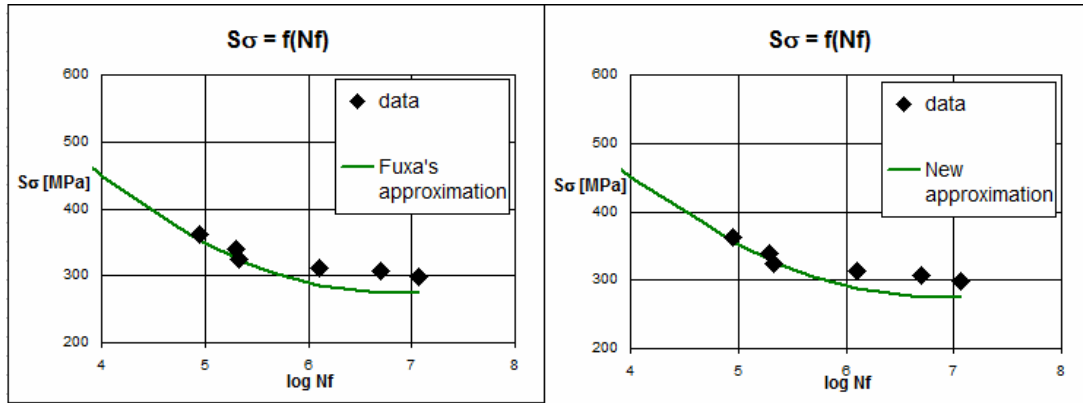

Fig. 5 S-N curve for alternating bending

## 7 CONCLUSIONS

The four sets of experiment manufactured from the construction steel 11523, melt T31052 are introduced in this contribution. All experiments were realized at the reconstructed testing device which was equipped by the fixative jaw. Using those jaws the dynamical loading of the specimen by the torque, bending and by the combination of both loadings is possible. The experiments were performed with the frequency of 25Hz and in case of the combined loading the loading parameters were in phase. The required values of stress intensity and of the reference stress were obtained for all cases by the FEM analysis in the software ANSYS.

First experiment – alternating torsion. The obtained results of the stress intensity as the function of number of cycles are stated in Tab. 1 and Fig. 2. Those experimental data was used in the constants calculation of the Fuxa's and new approximation. The calculated constants were used for the evaluation of the following experiments. Both used approximations embody the good agreements with the performed experiment. The absolute value of the mean relative error is in "average" lower in case of the new approximation.

Second experiment – alternating torsion and bending under the angle of 30 degrees. The experiments were performed under the same conditions as in previous cases. The specimen were fixed in the testing device at the angle of 30 degrees against the rotation axis. The obtained values of stress intensity and of reference normal stress as the function of number of cycles until the crack initiation are stated in Tab. 2 and Fig. 3. The results were approximated by the curve of Fuxa's and new approximation, where the constants determined in the first experiment were used. Both used approximations embody the good agreements with the performed experiment. The absolute value of the mean relative error is in "average" lower in case of the new approximation.

Third experiment – alternating torsion and bending under the angle of 60 degrees. The experiments were performed under the same conditions. The specimen were fixed in the testing device at the angle of 60 degrees against the rotation axis. The obtained values of stress intensity and of reference normal stress as the function of number of cycles until the crack initiation are stated in Tab. 3 and Fig. 4. The results were approximated by the curve of Fuxa's and new approximation, where the constants determined in the first experiment were used. Both used approximations embody the good agreements with the performed experiment. The absolute value of the mean relative error is in "average" lower in case of the new approximation.

Fourth experiment – alternating bending. Those measurements were performed in the identical testing jig, however, the specimen was turned by 90 degrees. The experiments were performed under the same conditions. The obtained values of stress intensity and of reference normal stress as the function of number of cycles until the crack initiation are stated in Tab. 4 and Fig. 5. The results were approximated by the curve of Fuxa's and new approximation, where the constants determined in the first experiment were used. Both used approximations embody the good agreements with the performed experiment.

## Acknowledgements

*The paper was created under support of GACR, project no: 101/08/P141.*

## REFERENCES

- [1] FOJTÍK, F. The Fatigue Testing Machine and Experiment. In *Applied Mechanics 2008*. Wisla: Poland, 2008, pp. 11-13. ISBN 978-83-60102-49-7.
- [2] FOJTÍK, F. The *Experimental Machine for the Multiaxis Fatigue Testing of Material*. Dissertation Thesis. Ostrava: VŠB-TU Ostrava, 2007.
- [3] FUXA, J. & FOJTÍK, F. & KUBALA, R. Torque machine fit for high cycle fatigue of material testing. In *Experimental Stress Analysis 2007*. Hotel Výchledy: Czech Republic, 2007, pp. 37-39. ISBN 978-80-7043-552-6.
- [4] FUXA, J. & KUBALA, R. & FOJTÍK, F. & PORUBA, Z. Reconstruction of the Torque Test Machine and Its Utilization for Strength Criterion Searching. In *Experimental Stress Analysis 2005*. Skalský dvůr: Czech Republic, 2005, pp. 23-25. ISBN 80-214-2941-0.
- [5] FUXA, J. & KUBALA, R. & FOJTÍK, F. Idea of Conjugated Strength. In *Experimental Stress Analysis 2006*. Červený Kláštor: Slovensko, 2006, pp. 125-130.
- [6] FOJTÍK, F. & FUXA, J. Examination of the Fatigue Life under Combined Loading of Specimens. *Applied and Computational Mechanics*. 2008, Vol. 2, No 1, pp. 37-44. ISSN 1802-680X.
- [7] MACURA, P. *Experimentální metody v pružnosti a plasticitě*. script VŠB – TU Ostrava, 2006. 107 pp. ISBN 80-7078-934-4.

